

Scalability in the Genifax Enterprise Network Fax Solution



Overview

The Genifax network fax solution is built on the foundation of the Omttool Message Server. Our goal for both the product and the core architecture was to provide our most demanding enterprise customers with both flexibility and scalability options. Flexibility allows a customer to design and deploy the product in a way that best complements their existing messaging and telecommunications infrastructure. Scalability provides the customer with the ability to start small and then expand over time and insures that the system is always available and can process hundreds of thousands of fax documents per month.

The Omttool Message Server — An Architecture Built for Scalability

Genifax's clustering implementation is based on the foundation of the underlying architecture of the Omttool Message Server. In particular, there are two key aspects of this architecture that are essential to support clustering: the relational database-based work queue and the component-based implementation of major system processes.

The Genifax work queue is stored in relational database tables. These tables can be maintained using MSDE and MS SQL Server database engines. Genifax leverages the capabilities of the relational database system to provide data integrity, high-availability and high throughput access to this information. Any number of processes on any number of systems running in a network can access the data in the relational database. Transaction control and data integrity are ensured by the database server.

Simple, single-server installations might use a simple MS Access database located on the same physical system as the fax server programs as the repository for this work queue information. More demanding high-availability, installations incorporate data centers might off-load the Genifax work queue to be maintained within separate, pre-existing, SQL Server database servers. In both cases, Omttool is leveraging the sophistication of the database engine rather than relying on a proprietary implementation of a work queue that is specific to the fax server product and vendor. Traditional fax servers rely on proprietary implementations of work queues that are unable to deliver high-availability and high-performance requirements demanded by centralized messaging infrastructures.

The second key aspect of the Omttool Message Server architecture to support clustered, high-availability systems is its component-based implementation of major system processes. Each major task of the fax server is implemented as its own, discreet software module: the Exchange connector, the Notes connector, the core document conversion process, the Telco/Modem management connector, and so forth. Each of these components communicates with the core message server and work queue in order to identify when it has work that is ready for it to process and to update the work queue once it has completed it's processing. The server can have multiple processes of the same type running at the same time – multiple telco servers, for example. While all the members of the cluster are up and running, they work together to process the volume of fax messaging traffic. Should any member of the cluster fail, the other members of the cluster that continue to operate can continue processing work without a single fax message or phone call being lost!

This component-based architecture allows an administrator to configure clustered systems comprised of multiple, redundant processes that can operate together to deliver high-throughput, load-balanced processing as well as fail-over, fault-tolerant operation.

The database-based work queue ensures that all processes have constant and reliable access to information about the documents to process. The component-based architecture of the core system processes allows the administrator to configure as many processes on as many physical systems as necessary to handle the workload and ensure fault-tolerant, high-availability operation.

Scalability Features

Flexibility to support a variety of deployment configurations:

- Highly centralized data center configuration.
 - This is most often the architecture of choice for modern enterprises where the commodity cost of network bandwidth has become less expensive than the ongoing, human cost of system administration. Genifax supports high-availability, clustered configurations that may be required for deployment into these centralized data center environments.
- Highly decentralized server per facility configuration
 - This can be the ideal configuration to support decentralized organizations comprised of many physical offices, each of which has its own messaging server.
 - Genifax's 15-minute install and remote system management are key features when considering deployment of many individual fax servers.
- Hybrid configuration, with centralized message servers and decentralized modem/telco servers
 - Many companies want to manage their core message servers in centralized data centers and also want to have the ability to send and receive fax transmissions on phone lines and phone numbers that are local to their physical office locations.
 - The Genifax remote telco capability provides an ideal solution to meet both requirements. The sophistication (and complexity) of the core fax server can be installed and operated in a centralized corporate data center and the local-presence phone interface can be installed on specific telco servers that are put into the physical offices of the company and "homed in on" the core message server in the central data center. Complexity and cost is minimized in the remote facility while still providing the key feature of being able to send and receive faxes to and from the local office.
- Fax-Over-IP
 - Omtool supports hardware-based solutions for Fax-over-IP via Cantata Brooktrout TR1034 digital boards.

Reliability

- Clustered configurations can eliminate any single point of failure and therefore can deliver 99.9999% reliability in a truly fault-tolerant system.
-

Fast, Efficient

- Multi-threaded system components can work on multiple items simultaneously.
- Event-based inter-process notifications trigger work to be done rather than inefficient polling-based architectures where processes “wake up” periodically to check for work to be done.

Load Sharing

- In single-server configurations, core processes run multiple threads and each thread can work on its own document. Each thread is thread-safe, so if there is a failure of the thread it will not affect the other threads doing work on other documents.
- In clustered configurations, multiple instances of processes can be running on separate physical systems so that 1) when all systems are operating they all work together to share the work load and 2) if any individual system should fail the remaining systems will continue to operate and process the outstanding work.

Dedicate Systems to Specific Tasks

- System resource intensive tasks – the document conversion process and the telecommunications/fax modem interface – can be off-loaded from the core message server to separate physical systems, providing them with the entire resources of a dedicated host system.

Expansion

- Start with a simple single-server deployment and then have the ability to expand over time to meet increasing number of users and volume of fax traffic.
- A single-server system can be expanded by:
 - Off-loading specific, resource-intensive processes to separate, dedicated systems.
 - Installing in remote offices Genifax remote telco servers specifically focused on managing the fax modem interface for telecommunications lines connected in that office. Remote telco servers are not full fax servers, but instead thin “telco-only” servers that are homed in on a managed through complete fax servers that are installed and running in a central data center.
 - Installing additional complete fax servers, either as a member of a centralized fax server cluster in the same location as the original server or as a completely separate stand-alone server in new location.
- None of these expansions require the administrator to fundamentally redesign the previous fax server installation. As the volume of work to process and the number of and locations of users expands, the fax server infrastructure to support that volume and those users can simply be added on without having to change the existing, original fax server implementation.

Minimize Impact on Other Non-fax Systems

- Genifax connectors link the fax server to messaging servers, application servers and other systems within the enterprise.
 - These Genifax connectors are installed and operate on the fax server system entirely. They are not installed on the messaging server or on the application server that the fax server communicates with. This minimizes any possible instability or performance impact that the fax server may have on these existing systems.
-

- Many traditional network fax solutions require the installation and management of fax server components on the Exchange or Notes messaging servers or on the SAP, Oracle, Siebel or other application servers.

Optimized for Communication with Clustered Messaging Servers

- Genifax has been designed to fully support messaging and application servers that are implemented in clustered configurations.
- For example, if the message server is clustered using Windows 2000 or 2003 Advanced Server clustering technology, and if a member of that cluster fails, the Genifax server will detect this failure and automatically connect to another member of the cluster without requiring any manual intervention by a system administrator. Traditional fax server solutions require manual intervention by the system administrator to stop and restart the fax server to message server gateway in order to re-establish connectivity to the message system cluster.

Global Product, Global Support

- Full support for Unicode to support processing of documents and information created in any worldwide language, even multi-byte character languages of many non-European languages.
 - Omtool has a record of selling and supporting the largest global enterprises in worldwide system deployments.
 - Omtool offers a variety of enterprise support plans, including and up to 24/7 support comprised of support engineers dedicated to meet the needs of a specific enterprise customer.
-

Related Features

Windows 2000 or 2003-Centric Administration

- Genifax is easy to manage because all of its system administration programs are implemented in the Windows 2000 or 2003-style, Microsoft Management Console-based environment.
- Genifax is fully integrated with the Windows Event Log and Performance Monitor providing ready access to information about fax server operations to the administrators and third-party administration programs that use these tools to monitor systems.
- Administrators do not have to learn the proprietary implementation of fax server administration programs used in legacy fax server products. If you are familiar with Windows administration tools you will be comfortable with Genifax administration.

Remote Management of Multiple Systems and System Components

- Genifax's MMC-based administration interface allows the fax system administrator to access the fax server, either to review the status of the current work queue or to review and manage the fax server configuration information.
 - The ability to manage many systems simultaneously is particularly important in large-scale, global deployments including many servers and system components.
-

Genifax Server to Server Routing

- Genifax Server to Server Routing capabilities allow a Genifax server to transfer outbound fax jobs to another Genifax server, one that may be in the same company but running in another data center in another country. Server to Server Routing can accomplish Least Cost Routing of outbound faxes through servers that are closer to the end fax number destination of the fax.
- Genifax Server to Server routing is particularly useful in large-scale global deployments where a company has multiple global data centers, each of which with one or more fax servers.

Genifax Server to Service Provider Routing

- The Genifax EasyLink Connector allows a Genifax server to transfer outbound faxes to the Easylink Internet Fax Service for delivery to its final destination. Deploying this hybrid fax server-fax service provider architecture allows companies to use the system integration and monitoring capabilities of the fax server and effectively outsource to EasyLink the fax modem/telecommunications interface that can be costly and complex, particularly in large-scale global deployments.

SAMPLE CONFIGURATIONS

1. Simplest, single-server, single board implementation

- 1 = Exchange Server
- 2 = Genifax Server

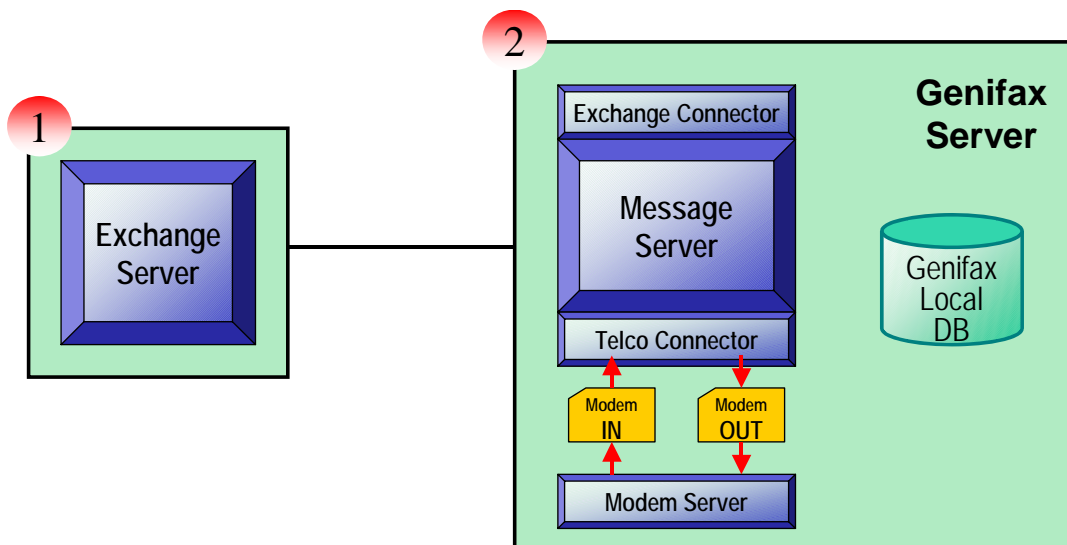

2. Redundant single server, multiple modem implementation

1 = Exchange Server

2 = Genifax Server

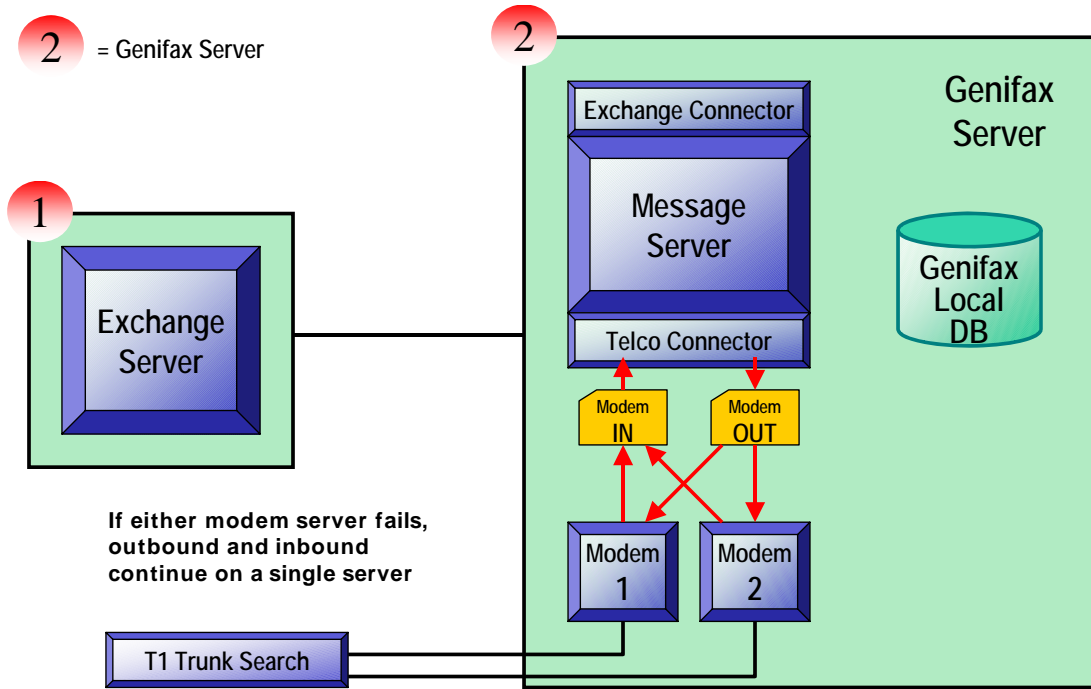

3. Remote office modem server

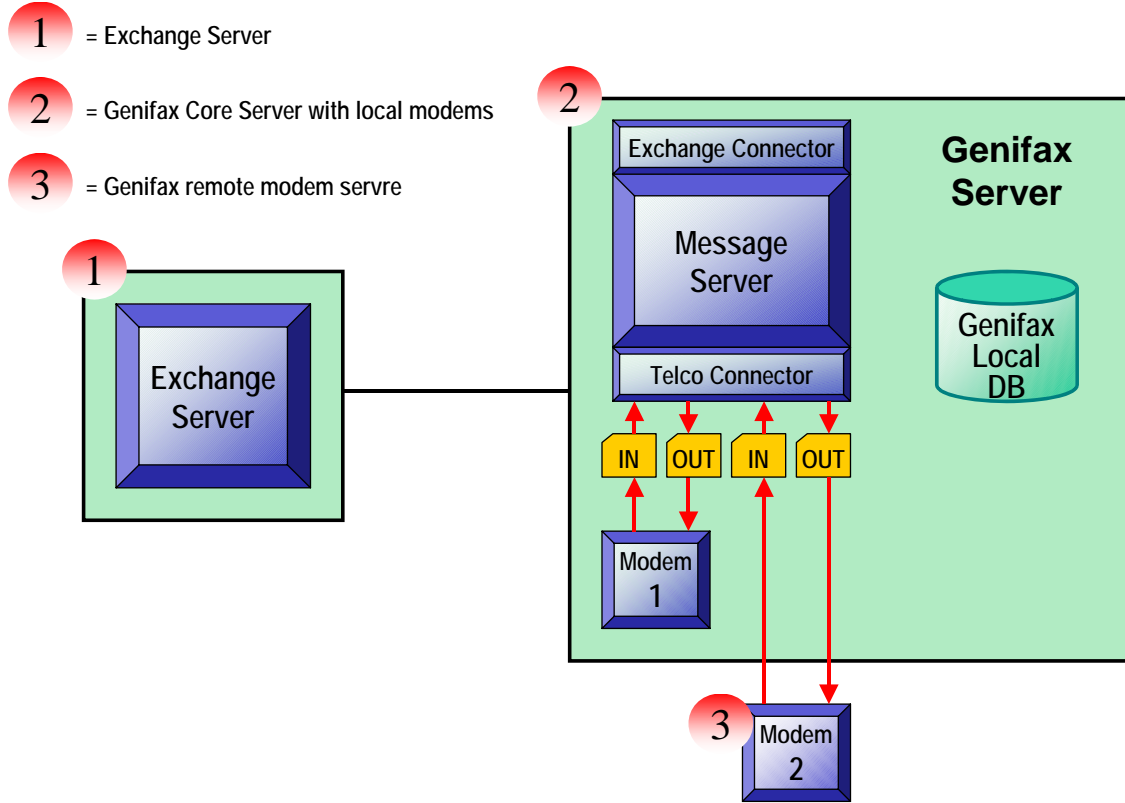

4. Fully redundant cluster

- 1 + 2 = Exchange server cluster
- 3 + 4 = SQL server cluster
- 5 + 6 = Genifax server cluster
- 7 + 8 = File server cluster
- 9 + 10 = Genifax remote modem servers

